

# ELECTRIC VIOLIN

## EV-204/EV-205

### Owner's Manual

### *Congratulations!*

*Thank you for purchasing the Yamaha Electric Violin. In order to obtain the maximum performance and enjoyment from your Electric Violin, we urge you to read this Owner's Manual thoroughly before using the instrument. Please keep this Owner's Manual in a safe place for later reference.*

### Contents

<b>Precautions</b> .....	<b>3</b>
<b>Main Body/Accessories</b> .....	<b>4</b>
<b>Nomenclature</b> .....	<b>5</b>
<b>Setup</b> .....	<b>7</b>
■ Installing the Bridge .....	7
■ Tuning .....	8
■ The Shoulder Rest .....	8
■ Changing Strings .....	9
<b>Power Supply</b> .....	<b>11</b>
<b>Using the Controls</b> .....	<b>12</b>
■ About the Controlled Mode .....	12
■ Using Headphones .....	13
■ Controlling the Output Volume (Master Volume) .....	13
<b>Example Connections</b> .....	<b>14</b>
<b>Specifications</b> .....	<b>15</b>

## FCC INFORMATION (U.S.A.)

### 1. IMPORTANT NOTICE: DO NOT MODIFY THIS UNIT!

This product, when installed as indicated in the instructions contained in this manual, meets FCC requirements. Modifications not expressly approved by Yamaha may void your authority, granted by the FCC, to use the product.

### 2. IMPORTANT:

When connecting this product to accessories and/or another product use only high-quality shielded cables. Cable/s supplied with this product MUST be used. Follow all installation instructions. Failure to follow instructions could void your FCC authorization to use this product in the USA.

### 3. NOTE:

This product has been tested and found to comply with the requirements listed in FCC Regulations, Part 15 for Class "B" digital devices. Compliance with these requirements provides a reasonable level of assurance that your use of this product in a residential environment will not result in harmful interference with other electronic devices. This equipment generates/uses radio frequencies and, if not installed and used according to the instructions found in the user's manual, may cause interference harmful to the operation of other

electronic devices. Compliance with FCC regulations does not guarantee that interference will not occur in all installations. If this product is found to be the source of interference, which can be determined by turning the unit "OFF" and "ON", please try to eliminate the problem by using one of the following measures:

Relocate either this product or the device that is being affected by the interference.

Utilize power outlets that are on different branch (circuit breaker or fuse) circuits or install AC line filter/s.

In the case of radio or TV interference, relocate/reorient the antenna. If the antenna lead-in is 300 ohm ribbon lead, change the lead-in to coaxial type cable.

If these corrective measures do not produce satisfactory results, please contact the local retailer authorized to distribute this type of product. If you cannot locate the appropriate retailer, please contact Yamaha Corporation of America, Electronic Service Division, 6600 Orangethorpe Ave, Buena Park, CA 90620

The above statements apply ONLY to those products distributed by Yamaha Corporation of America or its subsidiaries.

## SPECIAL MESSAGE SECTION

This product utilizes batteries or an external power supply (adaptor). DO NOT connect this product to any power supply or adaptor other than one described in the manual, on the name plate, or specifically recommended by Yamaha.

This product should be used only with the components supplied or: a cart, rack, or stand that is recommended by Yamaha. If a cart, etc., is used, please observe all safety markings and instructions that accompany the accessory product.

**SPECIFICATIONS SUBJECT TO CHANGE:** The information contained in this manual is believed to be correct at the time of printing. However, Yamaha reserves the right to change or modify any of the specifications without notice or obligation to update existing units.

Do not attempt to service this product beyond that described in the user-maintenance instructions. All other servicing should be referred to qualified service personnel.

This product, either alone or in combination with an amplifier and headphones or speaker/s, may be capable of producing sound levels that could cause permanent hearing loss. DO NOT operate for long periods of time at a high volume level or at a level that is uncomfortable. If you experience any hearing loss or ringing in the ears, you should consult an audiologist.

**IMPORTANT:** The louder the sound, the shorter the time period before damage occurs.

**NOTICE:** Service charges incurred due to a lack of knowledge relating to how a function or effect works (when the unit is operating as designed) are not covered by the manufacturer's warranty, and are therefore the owner's responsibility. Please study this manual carefully and consult your dealer before requesting service.

**ENVIRONMENTAL ISSUES:** Yamaha strives to produce products that are both user safe and environmentally friendly. We sincerely believe that our products and the production methods used to produce them meet these goals. In keeping with both the letter and the spirit of the law, we want you to be aware of the following:

**Battery Notice:** This product MAY contain a small non-rechargeable battery which (if applicable) is soldered in place. The average life span of this type of battery is approximately five years. When replacement becomes necessary, contact a qualified service representative to perform the replacement.

This product may also use "household" type batteries. Some of these may be rechargeable. Make sure that the battery being charged is a rechargeable type and that the charger is intended for the battery being charged.

When installing batteries, do not mix old batteries with new, or with batteries of a different type. Batteries MUST be installed correctly. Mismatches or incorrect installation may result in overheating and battery case rupture.

**Warning:** Do not attempt to disassemble or incinerate any battery. Keep all batteries away from children. Dispose of used batteries promptly and as regulated by the laws in your area. Note: Check with any retailer of household type batteries in your area for battery disposal information.

**Disposal Notice:** Should this product become damaged beyond repair, or for some reason its useful life is considered to be at an end, please observe all local, state, and federal regulations that relate to the disposal of products that contain lead, batteries, plastics, etc. If your dealer is unable to assist you, please contact Yamaha directly.

**NAMEPLATE LOCATION:** The nameplate is located on the bottom of the product. The model number, serial number, power requirements, etc., are located on this plate. You should record the model number, serial number, and the date of purchase in the spaces provided below and retain this manual as a permanent record of your purchase.

Model

Serial No.

Purchase Date

92-BP

## PLEASE KEEP THIS MANUAL

## CANADA

THIS DIGITAL APPARATUS DOES NOT EXCEED THE "CLASS B" LIMITS FOR RADIO NOISE EMISSIONS FROM DIGITAL APPARATUS SET OUT IN THE RADIO INTERFERENCE REGULATION OF THE CANADIAN DEPARTMENT OF COMMUNICATIONS.

LE PRESENT APPAREIL NUMERIQUE N'EMET PAS DE BRUITS RADIOELECTRIQUES DEPASSANT LES LIMITES APPLICABLES AUX APPAREILS NUMERIQUES DE LA "CLASSE B" PRESCRITES DANS LE REGLEMENT SUR LE BROUILLAGE RADIOELECTRIQUE EDICTE PAR LE MINISTERE DES COMMUNICATIONS DU CANADA.

- This applies only to products distributed by Yamaha Canada Music Ltd.
- Ceci ne s'applique qu'aux produits distribués par Yamaha Canada Musique Ltée.

**Your Electric Violin will give you years of reliable service if you follow the simple rules given below:**

### ■ Location

Do not expose it to the following conditions to avoid deformation, discoloration, or more serious damage.

- Direct sunlight (e.g. near a window).
- High temperatures (e.g. near a heat source, outside, or in a car during the daytime).
- Excessive humidity.
- Excessive dust.
- Strong vibration.

### ■ Turn Power OFF When Making Connections

- To avoid damage to the Electric Violin and other devices to which it is connected (a sound system, for example), turn the power switches of all related devices OFF prior to connecting or disconnecting audio cables.

### ■ Handling and Transport

- Never apply excessive force to the controls, connectors or other parts.
- Always unplug cables by gripping the plug firmly, not by pulling on the cable.
- Disconnect all cables before moving the unit.
- Physical shocks caused by dropping, bumping, or placing heavy objects on the unit can result in scratches and more serious damage.

### ■ Cleaning

- Clean the cabinet and panel with a dry soft cloth.
- A slightly damp cloth may be used to remove stubborn grime and dirt.
- Never use cleaners such as alcohol or thinner.
- Avoid placing vinyl objects on top of the unit (vinyl can stick to and discolor the surface).

YAMAHA is not responsible for damage caused by improper handling or operation.

# Main Body/Accessories

After opening the packaging, please check that all the parts listed below are included.

- Violin

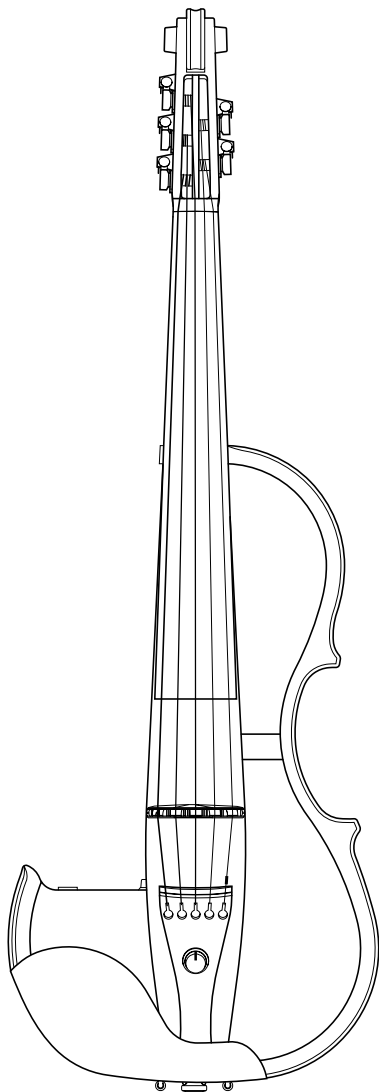

- 6F22 (S-006P) 9V battery x 1

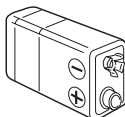

- Owner's Manual

\* The EV-205 is the illustration.

# Nomenclature

## ● Front

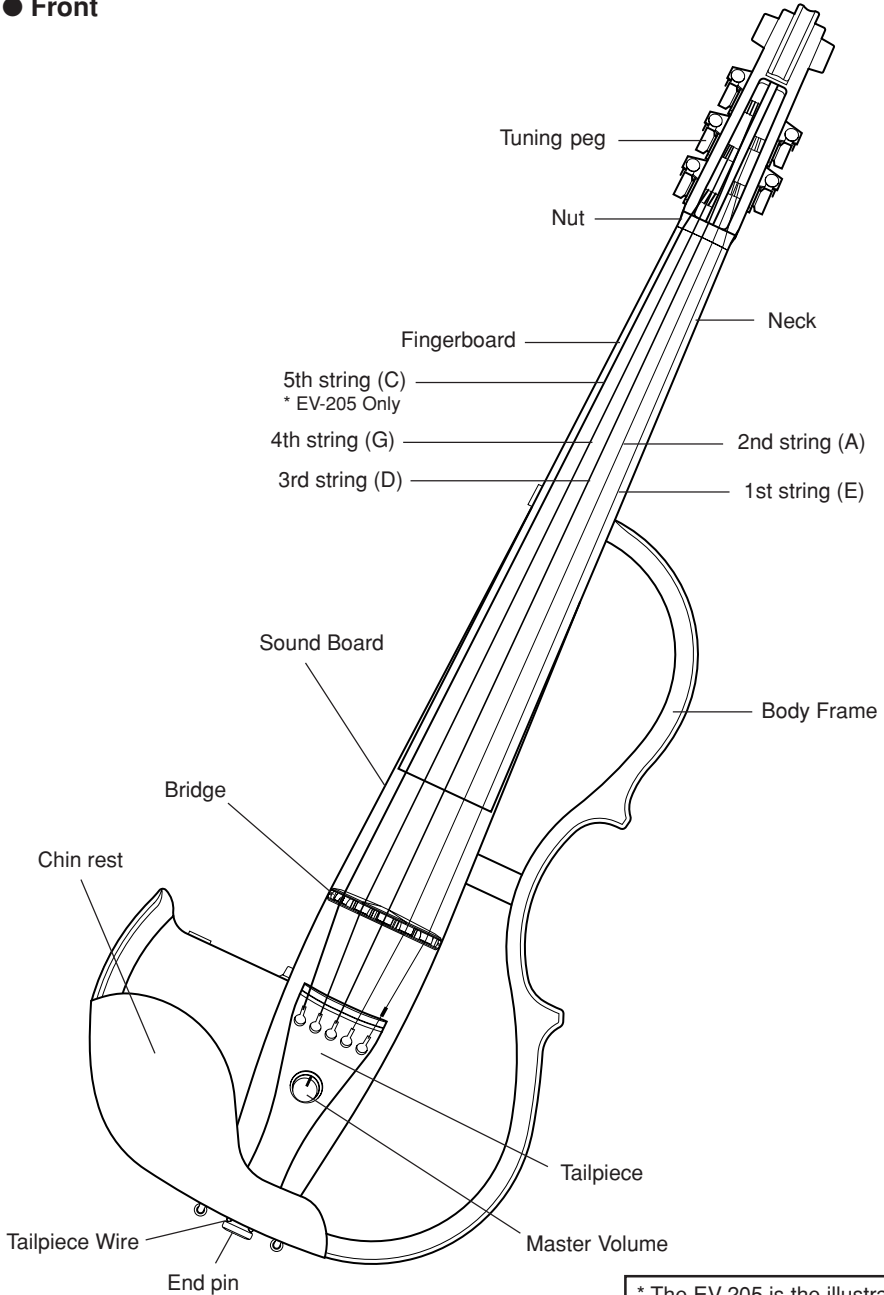

\* The EV-205 is the illustration.

● Controls

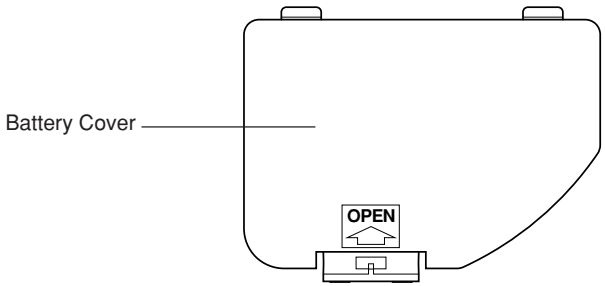
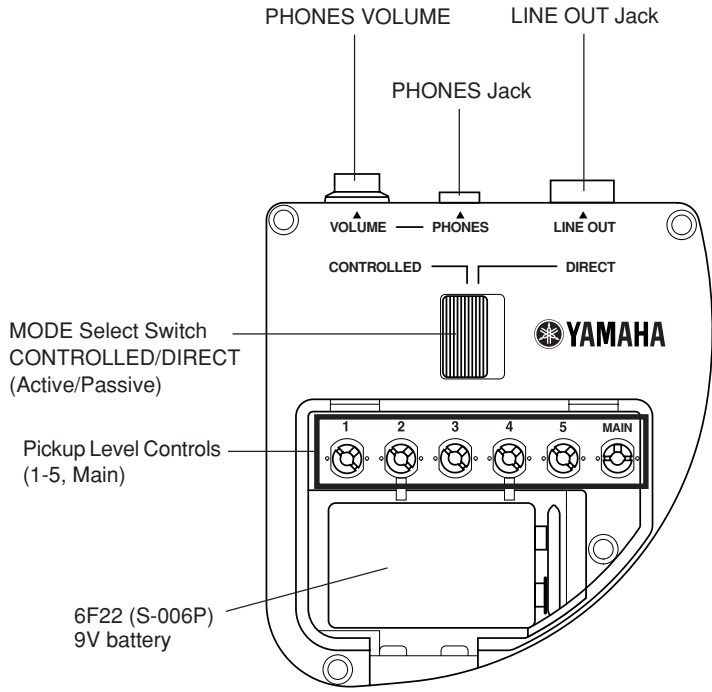

# Setup

## ■ Installing the Bridge

- The lower side of the bridge supports the 1st string (E), the higher side supports the 4th string (G). Make sure the bridge is placed properly.
- Make sure that the tailpiece side of the bridge is standing vertically in relation to the violin's body. If the bridge is leaning to one side, loosen the strings and gently adjust the bridge with both hands. Also, make sure that each string passes over its corresponding notch in the bridge.
  - \* **Playing the violin with a bridge that leans may result in damage to the bridge or a deterioration in sound quality.**

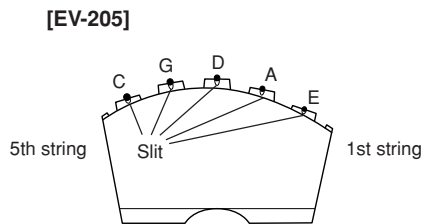
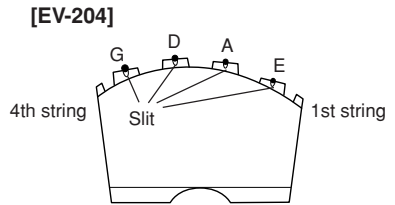

[Looking from the tailpiece]

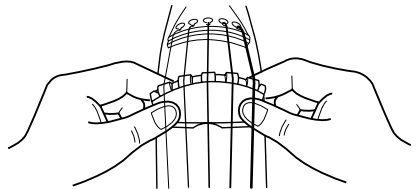
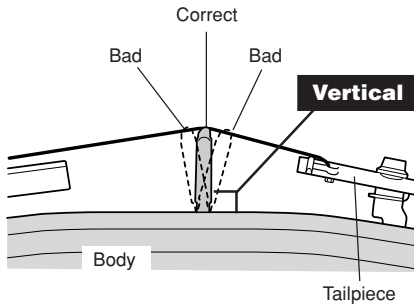

[Bridge is placed vertically]

## ■ Tuning

- The strings are tuned to the following pitches. The 1st string is tuned to E, the 2nd string to A, the 3rd string to D, the 4th string to G and the 5th string to C (EV-205).

Use a piano, tuning fork, tuner, etc. and adjust the pitch of each string using the pegs.

- After tuning is complete, make sure that the tailpiece of the bridge is still properly aligned. If the bridge is leaning in either direction, slightly loosen the strings and carefully re-align the bridge using both hands.

[EV-204]

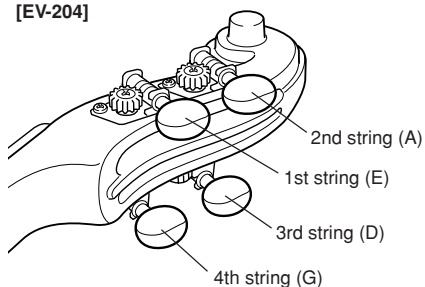

[EV-205]

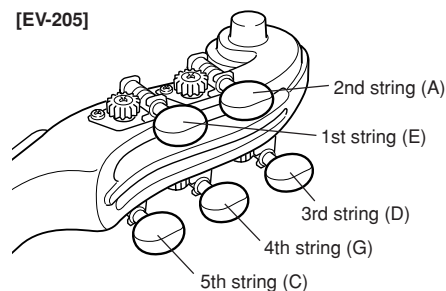

## ■ The Shoulder Rest

Most standard size (4/4) violin rests can be attached to the body of the Electric Violin.

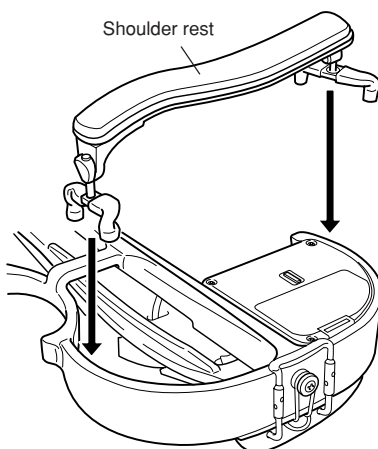

Natural wood is used for some parts in this instrument. Depending upon the manner in, or the circumstance under which the instrument is used, your fingers, body or clothes may become blackened or the wood parts may change color. If your fingers or body become blackened, it is not harmful but please wash with water thoroughly. The maker takes no responsibility for any discoloration of clothes or wood parts.



## ■ Changing Strings

As the strings get old, sound quality will gradually degrade, and the instrument will become difficult to tune. Change the strings as soon as you think they are getting old.

When changing strings, use Yamaha strings designed especially for the instrument. These strings are specially designed to eliminate electric noise.

Always change the strings one at a time, even if all strings must be changed.

- The end of the strings are sharp and can cut fingers. Use caution when changing strings.
- When changing or adjusting strings, do not put your face close to the instrument. The string may suddenly break resulting in eye or other unexpected injuries.

### 1 Attach the string to the tailpiece.

- From above the tailpiece, insert the ball end of the string into the hole on the tailpiece and hook the ball end into the notch of the string hole.
- At this time, make sure the string's ball end comes in contact with the shielding sheet attached to the underside of the tailpiece.

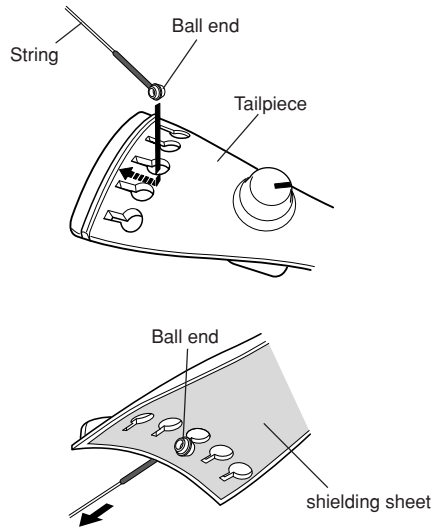

[Looking from the underside of the tailpiece]

### Caution

- Make sure that the tailpiece wire is properly positioned around the endpin.

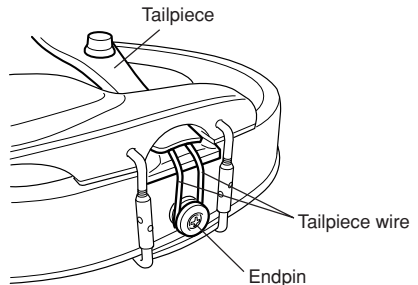

2 Insert the string into the hole on the peg and wind the string onto the peg.

- Wind the **1st (E) and 2nd (A)** strings to the left of the hole as shown in the illustration on the right.
- Wind the **3rd (D), 4th (G) and 5th (C)** strings to the right.

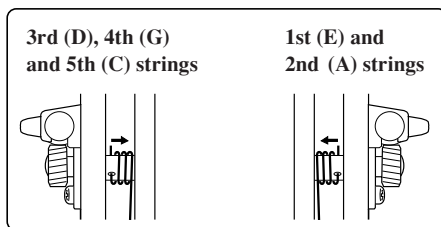

**Caution** • The string wrapped two or three times around the peg makes the most suitable condition for tuning the violin. Too many or too few wraps may result in inaccurate tuning or noise while playing.

Make sure that the strings do not pull on the bridge causing it to over toward the fingerboard. Also, make sure that the strings pass over their corresponding notch in the top of the bridge. (Make sure that the tailpiece side of the bridge is standing vertical in relation to the violin body.) If the 1st (E) string has a protective tube on it, slide this tube down onto the thicker, ball end of the string (wound with thread) so it does not cause noise and remains out of the way.

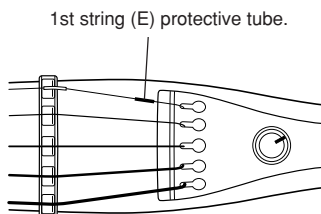

[EV-204]

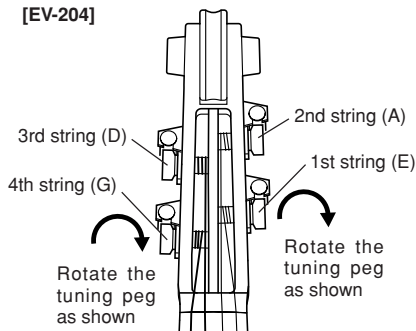

[EV-205]

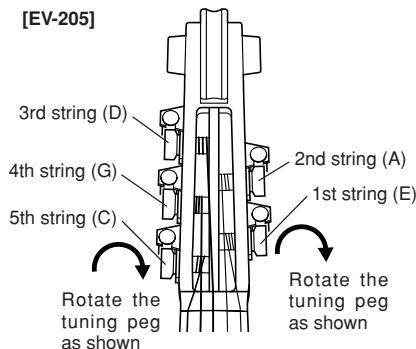

3 Use a piano, tuning fork, tuner, etc., and adjust the pitch of each string using the tuning pegs.

• When the instrument is not going to be used for an extended period of time, loosen the strings until the pitch drops a whole tone.

# Power Supply

The Electric Violin requires power when it is operated in the Controlled Mode, or with a pair of headphones. Power is supplied by a single 6F22 (S-006P) 9V battery.

Before preparing the power supply, make sure that the Control Section's LINE OUT and PHONES jacks are disconnected.

\* The Electric Violin operates without power in the Direct Mode.

**1** Open the battery case, located on the backside of the instrument, by pushing on the tab labeled "OPEN" and lifting open the battery compartment cover.

**2** Connect the supplied 9V battery (6F22:006P) to the battery snap. Take careful note of the polarity markings (+/-) as shown in the illustration.

Also, insert the battery at an angle and set so that it is positioned under the hook that holds the battery in place. (Refer to the illustration below.)

\* If the battery is inserted with force onto the hook, it may result in damage to the hook, etc.

**3** Place the battery in the battery compartment then close the battery compartment cover.

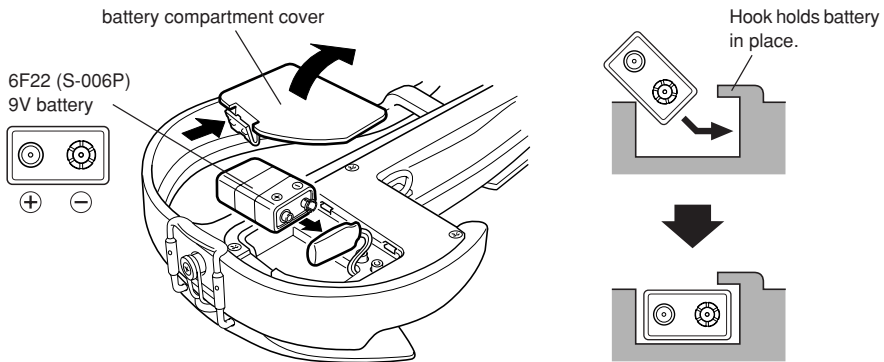

Bij dit produkt zijn batterijen geleverd. Wanneer deze leeg zijn, moet u ze niet weggooien maar inleveren als KCA.



When battery power is depleted, volume will be reduced or the sound will become distorted. In that case, please take careful note of the following precautions and replace the battery. For information average battery life, refer to the specifications section on page 15.

- Always follow the +/- signs when inserting the battery. Improper insertion may result in fire.
- To prevent possible damage to the unit due to battery leakage and unnecessary power drain, remove the battery from the unit when it is not going to be used for an extended period of time.

# Using the Controls

## ■ About the Controlled Mode

The instrument can be operated in one of two modes, the Direct (Passive) Mode or Controlled (Active) Mode. Use the Mode Switch ❶ on the Control Section found on the back of the violin to select the mode.

### DIRECT (Passive) Mode

In this mode, the signal produced by the pickup is sent, directly to the LINE OUT jack delivering the instrument's straight, unaltered tone.

This mode does not use the preamp therefore battery power is not required (the violin will operate without a battery).

\* However, if headphones are used, battery power is required even in the Direct Mode.

### CONTROLLED (Active) Mode

In this mode, the signals produced by each of the strings' pickups are sent to a built-in mixing amplifier before being sent to the LINE OUT jack. This mode offers control over the volume balance between the strings.

Battery power is required in this mode.

\* Set the Master Volume ❷ to its minimum level before switching modes. (→See page 13)

## ● Balancing the volume between the strings (Controlled (Active) Mode)

Remove the battery compartment cover and use the six controllers to balance the volume between the strings. Rotate the controller to the right (clockwise) to increase the volume, or rotate the controller to the left (counter-clockwise) to decrease the volume. The controllers default position is shown in the illustration below.

\* Controllers 1-5 ❷ correspond to the 1st through 5th strings.

\* Control #5 does not operate on the EV-204.

\* The MAIN control ❸ is used for adjusting the overall volume after mixing the output of strings 1-5.

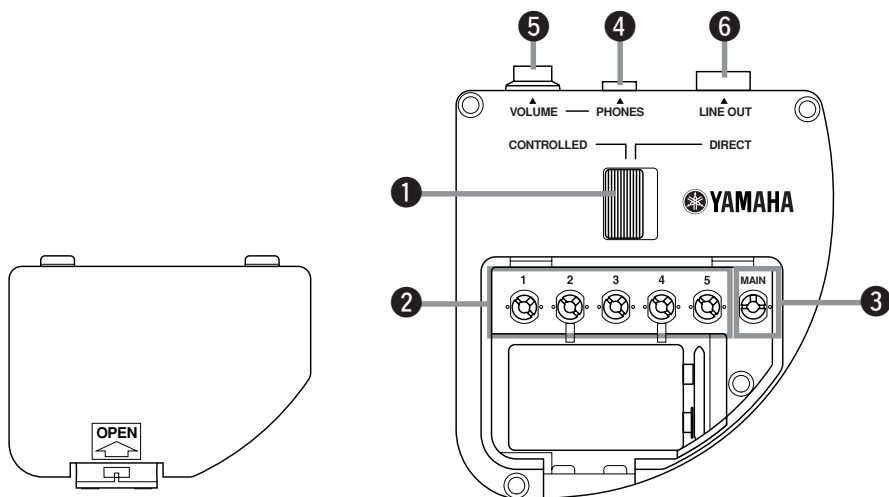

## ■ Using Headphones

Connect a pair of headphones, etc. to the PHONES jack (mini jack) ④ to monitor sound output. The VOLUME knob ⑤ can be used to control the monitor volume.

- \* The VOLUME ⑤ knob's setting does not effect the output of the LINE OUT jack.
- \* When a pair of headphones is used in the DIRECT Mode, battery power is required.

\* Do not operate the instrument at high volume levels when using earphones (headphones) for any extended period of time. Doing so can lead to irreparable damage to your hearing.

## ■ Controlling the Output Volume (Master Volume)

The knob ⑦ located on the tailpiece section is the Master Volume, which controls the volume of the output from the LINE OUT jack ⑥.

Rotate the knob to the right (clockwise) to increase volume, and rotate the knob to the left (counter-clockwise) to decrease volume. When the knob is fully rotated to the left, its level is "0" (no sound).

This knob functions in both Direct and Controlled modes.

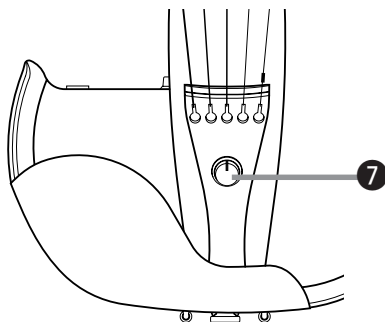

- Before connecting the Electric Violin to any external devices, make sure that the power of all external devices is turned OFF. Set the volume level of the Electric Violin and any external audio sources to the minimum level before connecting anything. High volume settings could cause damage to the equipment and your hearing.
- If a connection cord is unplugged while the power is ON, it may result in damage to the equipment. The sudden shock to your ears may be great, so please use with care.
- Be careful not to step on the cord. The cord may break, equipment may be damaged, and this may cause a substantial shock to your ears.
- Power is switched on when a plug is connected to one of the jacks. After playing, disconnect the plugs to save energy.

# Example Connections

Electric Violin

\* Both the LINE OUT and PHONES jacks are monaural type.

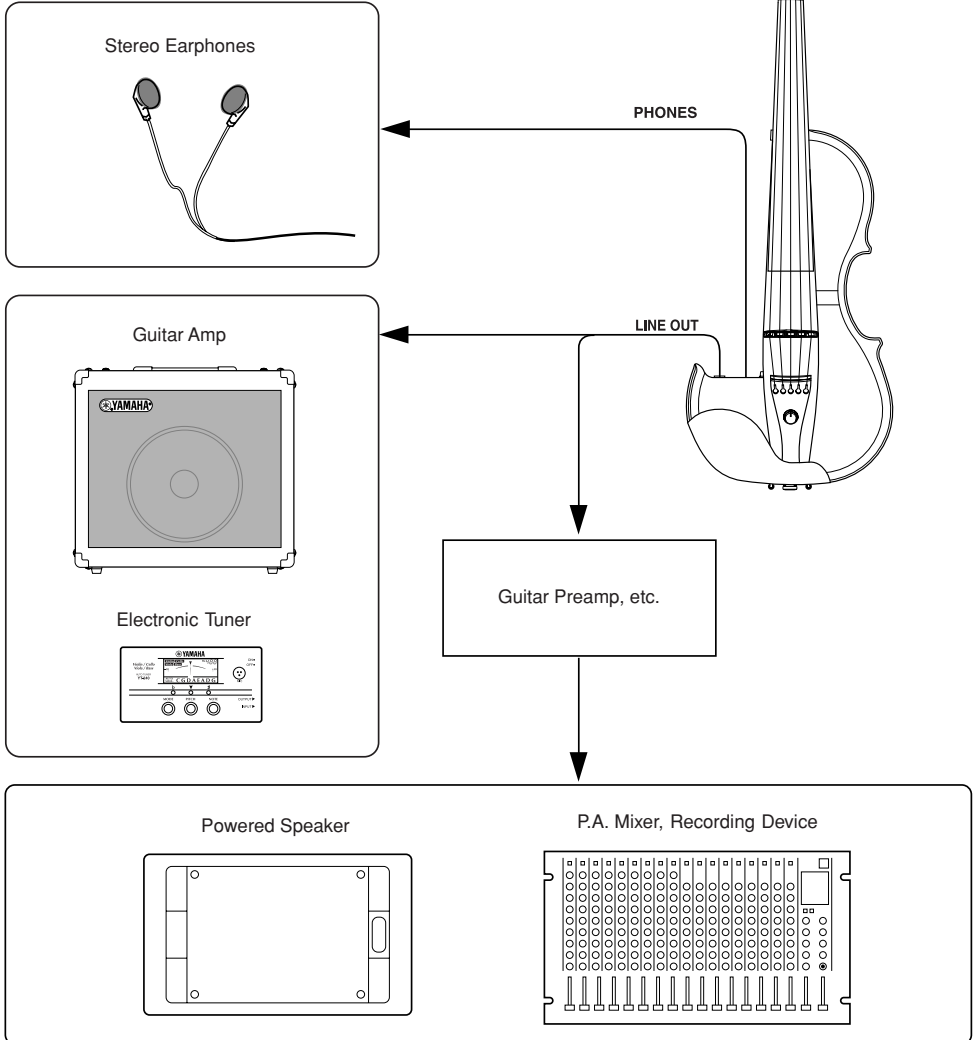

When connecting the instrument to external audio equipment, check the jack size and make sure to use a plug size that corresponds to the jack being used, and properly connect the cable to the jack.

# Specifications

<b>Neck</b>	Hard Maple
<b>Fingerboard/Nut</b>	Ebony
<b>Bridge</b>	Single Unit with Pickup
<b>Body Frame</b>	Maple
<b>Sound Board</b>	Maple
<b>Chin Rest</b>	Ebony
<b>Tailpiece</b>	<b>EV-204</b> : Ebony (4 hole type) <b>EV-205</b> : Ebony (5 hole type)
<b>Tuning Pegs</b>	Gear Type
<b>Strings</b>	YAMAHA strings for Electric Violin <b>EV4S</b> (strings for 4-string models)/ <b>EV5S</b> (strings for 5-string models) <b>EVS-1E</b> (1st)/ <b>EVS-2A</b> (2nd)/ <b>EVS-3D</b> (3rd)/ <b>EVS-4G</b> (4th)/ <b>EVS-5C</b> (5th)
<b>Pickup</b>	Individual high power output pickup for each string
<b>Connectors/Controls</b>	<ul style="list-style-type: none"> <li>• MODE Select Switch (CONTROLLED (Active)/DIRECT (Passive))</li> <li>• MASTER VOLUME</li> <li>• LINE OUT (with the power "ON" and a cable connected)</li> <li>• Pickup Level Controls <b>EV-204</b> : 4ch Mixer &amp; Main Volume <b>EV-205</b> : 5ch Mixer &amp; Main Volume</li> <li>• PHONES</li> <li>• PHONES VOLUME</li> </ul>
<b>Power Supply</b>	6F22 (S-006P) 9V battery x1
<b>Battery Life</b> (MODE=CONTROLLED, Continuous Use)	Used with headphones Manganese battery: approximately 6.5 hours Alkaline battery: approximately 15 hours Used without headphones Manganese battery: approximately 8 hours Alkaline battery: approximately 18 hours
<b>String Length</b>	328 mm (12-15/16")
<b>Dimensions</b>	<b>EV-204</b> :589 (L) x 206 (W) x 126 (H) mm 23-3/16" (L) x 8-1/8" (W) x 4-15/16" (H) <b>EV-205</b> :601 (L) x 206 (W) x 132 (H) mm 23-11/16" (L) x 8-1/8" (W) x 5-3/16" (H)
<b>Weight (with battery)</b>	717g (1 lbs. 9 oz.)
<b>Color</b>	AMBER, PEARL RED, COSMIC BLUE

\* Design and specifications are subject to change without notice.